

NOTE: THE "SEAL ORIENTATION LINE" INDICATES THE DIRECTION THAT THE OPEN SIDE OR THE SIDE OF THE SEAL WITH THE O-RING EXPANDER MUST FACE.

SEAL ORIENTATION LINE

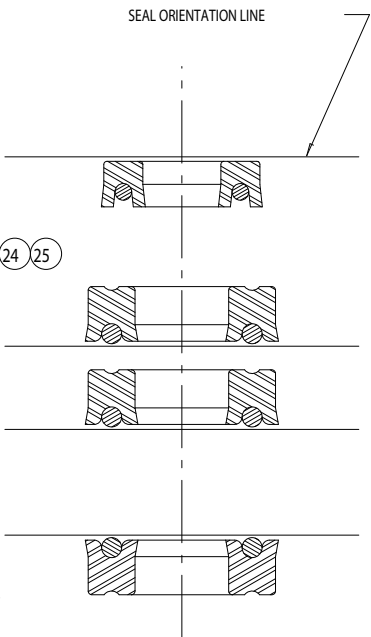

- = CRITICAL SPARE PART
- = SUGGESTED SPARE PART
- △ = OPTIONAL

PORT ORIENTATION

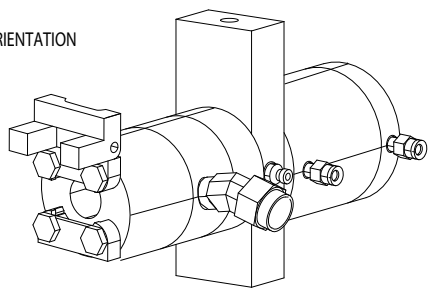

ITEM	QTY	PART NUMBER	SP	DESCRIPTION
32	1	268-33	△	OPTIONAL SEAL, UHMW
31	1	268-37	△	OPTIONAL AIR CAN SEAL
30	1	268-30	●	PISTON SEAL
29	1	268-29A		PISTON, ALUMINUM
28
27	2	258-27	○	WASHER, BRASS
26	4	268-26		1/4-20 HEX HEAD BOLT SS
25	1	X283-1		ZERK FITTING, 1/4NPTM
24	1	X084		FITTING 1/4NPTM 1/4TUBE
23	2	268-23		FITTING, 1/8NPTM 1/4TUBE
22	1	206-22	○	THRED SEAL
21	1	206-21A		10-32x.50" SOC BUT SS SELF-LOCK
20	1	258-20	○	RETAINING RING
19	4	221-06		10-32x.750" SOC CAP SS
18	1	258-18	○	RETAINING RING
17	1	258-17	○	WASHER, SS
16	2	268-16		1/4-20x1.0" SOC CAP SS
15	1	183-04		FITTING CLAMP
14
13	2	206-13	○	O-RING
12	1	257-01PU		VALVE MOUNT ASSY, PU
11	1	206-11	○	O-RING
10
9	1	268-09		ADHESIVE FITTING, 45°
8	1	183		HEAD ALIGNER ASSY
7	1	206-01		CAP, AIR CYLINDER
6	1	258-06		OUTLET, VALVE BODY
5	1	206-05		INLET, VALVE BODY
4	1	258-04		MOUNT SEGMENT, VALVE BODY
3	1	206-26	△	OPTIONAL - SPOOL, CERAMIC
2	1	206-07		SPOOL, SS
1	1	258-01		BODY, AIR CYLINDER

VALVE ASSEMBLY 268-VLLW375PUR

RECOMMENDED SPARES KITS

1	268-SA-WPU	SEAL KIT, WHITE PU SEALS
1	268-H	HARD KIT, STAINLESS SPOOL



5 Harris Court, Unit Q
 Monterey, CA 93940
 Tel: 831.642.6565
 Fax: 831.642.6563

NUMBER
268T

REV
A4

00
 0